



Katola

Installation Manual

STEEL TILE™
co.
METAL ROOFING MANUFACTURERS

GLOSSARY / TERMS

- AV Snips:** Hand snips for cutting metal.
- Building Paper:** A material installed over the roof deck prior to the application of the primary roof covering.
- Chalk Line:** A line made on the roof by snapping a taut string or cord dusted with chalk. Used for alignment purposes.
- Curb-Mounted Skylight:** A skylight that fits into a curb or frame, installed specifically around the opening in the roof.
- Dormer:** A framed window unit projecting through the sloping plane of a roof.
- Eaves:** Part of the roof that overhangs the wall of a building (bottom edge).
- Eaves Flashing:** Additional layer of roofing material applied to the bottom edge of the roof.
- Fascia:** Any cover board at the edge or eaves of a roof that is placed in a vertical position to protect the edge of the roof assembly.
- Flashing:** Pieces of metal or roll roofing used to prevent seepage of water into a building around any intersection or projection in a roof, such as vent pipes, chimneys, adjoining walls, dormers and valleys.
- Gable:** A triangle shape formed by a sloping roof.
- Gable Roof:** A type of roof containing sloping planes of the same pitch on each side of the ridge. Contains a gable at each end.
- Hand Benders:** Tool for bending metal sheets such as the Katola panels.
- Hip:** The external angle formed by the juncture of two slopes of a roof.
- Hip Roof:** A roof that slants upward on three or four sides.
- Junction Sheet:** Material applied above and underneath systems, behind sky lights and chimneys.
- Ridge:** The line where two planes of roof intersect, forming the highest point and running the entire length of the roof.
- Ridge Cap:** Material applied over the ridge or hip of a roof.
- Strapping:** 1" x 4" boards nailed over building paper or an existing roof, as a base to secure Katola panels.
- Trim:** Protects the seams anywhere on a roof, such as a hip or a ridge.
- Underlayment:** See "Building Paper."
- Valley:** The depression at the meeting point of two roof slopes.

Tools Required

- AV snips (never use a circular saw)
- Ladder (should reach from ground to eave at a safe angle)
- Hammer
- Wide-flanged pliers/hand benders
- Chalk line
- Rope
- Drill (minimum 4 amps) with 1/4" socket
- Measuring tape
- Caulking gun

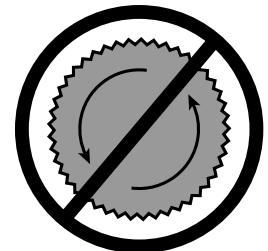

**Never use a circular saw
or any other rotating blade
to cut panels**

Calculating How Many Panels Are Needed

A single Katola panel covers an area 44.4" wide x 16" high, or 3.7' x 1.33' (this takes into account panel overlap). So a roof that is 20' wide would require 5.5 panels ($20 \div 3.7$) for one row across. If it is 12' from eave to peak, then it would be 9 panels ($12 \div 1.33$) high.

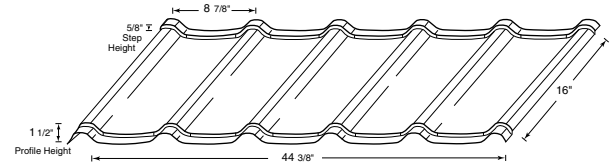

Roof 1

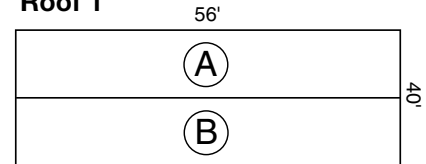

Roof 2

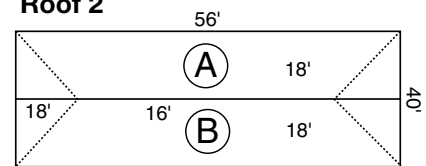

Roof 3

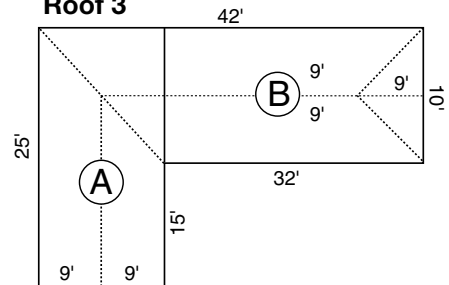

Roof 4

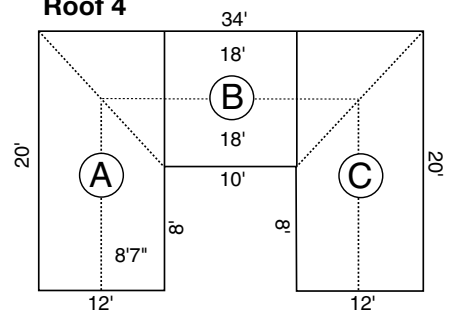

Roof 5

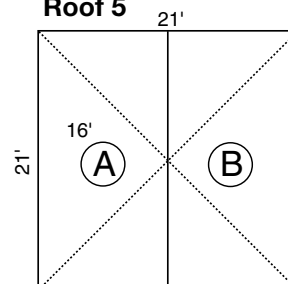

Tip: When measuring the roofs width, a partial panel may be required to complete the row, round up to a full panel for anything a half size or larger, and round up to a half panel for anything smaller. For example, a row that requires 5.4 panels would be rounded up to 5.5 panels. And a row requiring 5.5 panels would be rounded up to 6. When measuring the roofs height, fractional panels should be rounded up to the next whole number. A row of 5.4 panels becomes 6 panels.

Measure by Rectangles

To estimate how many panels are needed for a roof, make a sketch of it as if looking from directly above. Divide the roofs surface into a series of squares or rectangles that are measured separately and then added together. Here's how to measure and calculate panel coverage for five common roof types detail 1.1:

Roof 1: Simple Straight-Gable Roof. One side of the rectangle roof is 25' x 16' 7", which is 7 panels wide and 13 panels high. You would need 91 panels (7 x 13) per side, or 182 (91 x 2 sides) in total.

Roof 2: Cottage-Style Roof. The challenge is to account for the two hip ends (the sloping triangular parts). For now ignore the hip ends and calculate the roofs measurements as in Roof 1. One side of the rectangle would require 91 panels. To take into account the additional panels needed for a hip end, measure how many panels high it is and add that to the total. In this case the hip end is 18' or 14 panels high, from eave to peak. For one side of the roof you would need 105 panels (91 + 14). The entire roof requires 210 panels (105 x 2 sides).

Roof 3: L-Shaped Roof. Divide the roof into two rectangles (A & B). Rectangle A measures 25' wide x 9' high x 2 sides. This takes 98 panels (7 x 7 x 2). Rectangle B is 32' wide x 9' high x 2 sides. This is 126 panels (9 x 7 x 2). Then you have to take into account the hip end, which is 9' or 7 panels high. Rectangle B requires 133 panels (126 + 7). In total the roof needs 231 panels (133 + 98).

Roof 4: Horseshoe Roof. Divide into three rectangles (A, B & C). Rectangle A is 20' wide x 8' 7" high. This takes 77 panels (5.5 x 7 x 2 sides). Then take into account the hip end, which is 12' or 9 panels high. Altogether you would need 86 panels (77 + 9). Rectangle B is 10' wide x 8' 7" high x 2 sides. This requires 42 panels (3 x 7 x 2). Rectangle C is the same as A: 86 panels. So you need 214 panels (86 + 42 + 86) in total.

Roof 5: Hip Roof (four sloping triangles). Divide this into two equal rectangles (A & B). Rectangle A is 21' wide x 16' high. This requires 72 panels (6 x 12). The hip end is 16' or 12 panels high. You would need 84 panels (72 + 12) for this side. Rectangle B is the same as A: 84 panels. You need 168 panels (84 + 84) in total.

Tip: Katola panels come in bundles of 10, usually leaving you a few more panels than your estimate. The extras provide you with a margin for error.

2 INSTALLING THE KATOLA ROOF

When roofing an existing building, Katola panels can be installed on top of old shingles, saving time and money on removal and dumping fees. Trim all shingles flush with the fascia board. Inspect the plywood and joint locations. If the plywood is in poor condition, 1" by 4" strapping may need to be installed over the existing roof. Screws should not hit joints between plywood sheets, which would reduce their holding power. If you do start to hit a joint, move the screw down or over a little to avoid the joint.

If putting on a new roof, Katola panels can be installed on 1/2" plywood with approved building paper or on 1" x 4" rough-sawn wood strapping at 16" on edge with approved building paper.

Tip: *To stay safe on a steep-pitched roof, consider working on a ladder hung from the ridge. High buildings and power tools require extra care. Always check with the building inspector about safety issues and always follow local building codes.*

1a) Install Plywood

Install 1/2" plywood over the roofing framing, leaving a 2" gap at the ridge for ventilation. In areas where ice or snow dams are possible, or where the local building codes demand it, you must provide eave protection or underlay.

1b) Install Strapping

Install approved building paper on top of roof framing. Then install 1" x 4" rough-sawn strapping at 16" on edge (not 16" spaces, but 16" from the front edge of strapping to front edge of strapping), starting flush with the fascia board. The last 1" x 4" should be 2" down from the ridge with a second 1" x 4" nailed tightly against it, as shown in Detail 2.2.

The building paper should also be slit in this 2" gap, because the gap provides ventilation at the ridge. Strap around all vent pipes and turbines. Double up strapping at all hips and triple at all valleys, as shown in Detail 2.3.

Tip: *Store the roofing sheets in a dry place away from fertilizers, alkalis, salts and other corrosive agents. Prevent the stack of sheets from getting wet for extended periods of time. Any dampness between the sheets might start to cause discoloration of the painted surface. If the sheets get wet, separate them with a 1" x 2" strapping, and let dry.*

Detail 2.1: These areas may require special attention

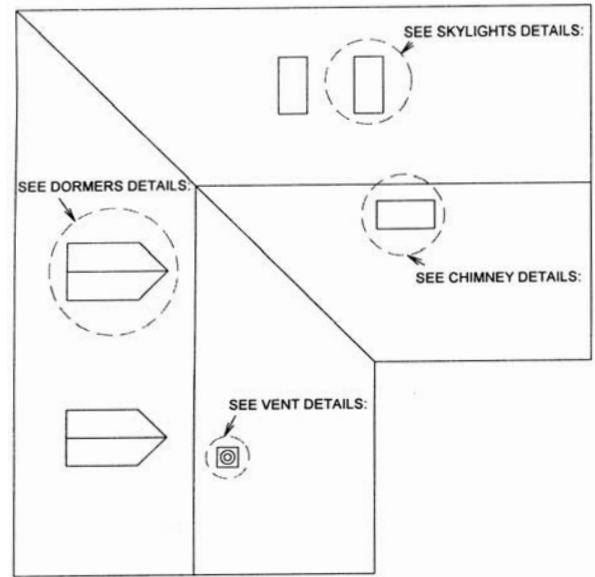

Detail 2.2

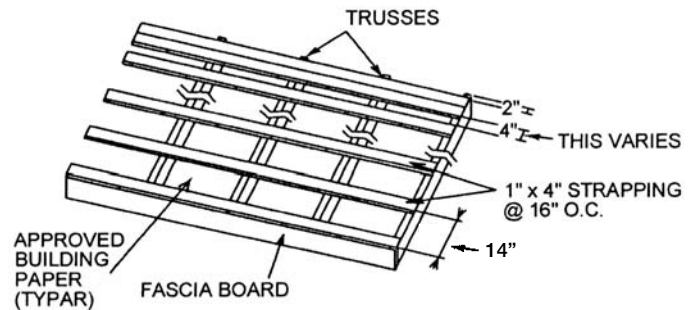

Detail 2.3

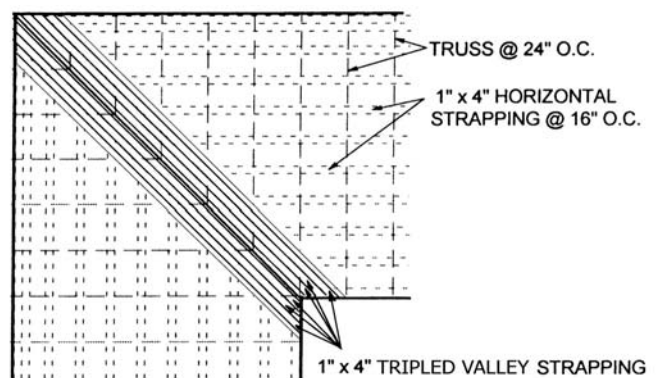

NOTE:

Katola installation guide lines should be applied as minimal standards. Always refer to local building codes for additional strapping, plywood or underlayment requirements.

2) Install Eave Trim

Follow Detail 3.1.

3) Install Valley Flashings

Start placing the valley flashing from the bottom of the valley. Push the valley flashing down to form the slopes of the roof. Screw the sides of the valley flashing to the 1/2" plywood or 1" x 4" strapping. Keep screws in the valley flashing as far from the centre as possible, as shown in Detail 3.3. Never cut the bottom of the valley flashing to form to the eaves. Allow a 1 1/2" overhang in the centre, tapered back to 1/2" at 4" over, and a 1/2" on the rest.

If overlapping is required to lengthen the valley flashing, overlap approximately 8" to 12". If the slope of the roof is low, then there should be more of an overlap. Insert the next valley flashing on top and apply Steel Tile approved silicone between the flashing.

Dormers: At the bottom of the valley, cut and fold the flashing, as shown in Detail 3.4. Cut and fold the roofing panel and fit the flashing into the panel, as shown in Detail 3.4

At the top of the valley flashing, draw a straight line on the valley flashing along the ridge. Cut 2" over, as shown in Detail 3.5. Fold the valley flashing along the ridge line, as shown in Detail 3.6 and install it over the first valley flashing. Use silicone between the overlapping flashings.

Detail 3.1

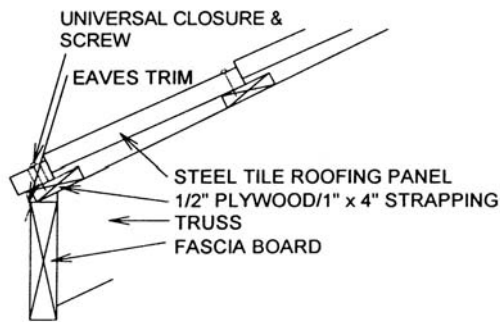

Detail 3.2: LEGEND

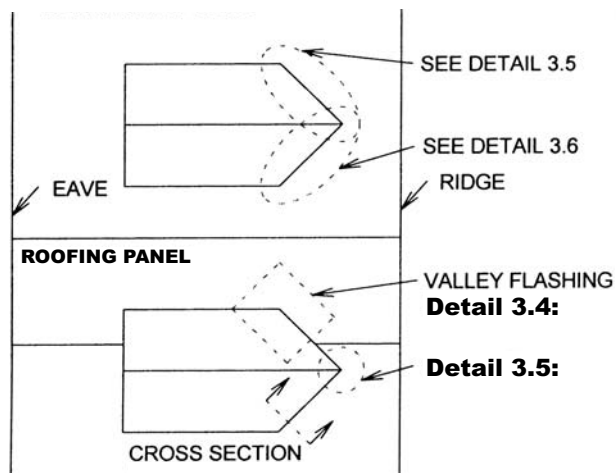

Detail 3.3: CROSS SECTION

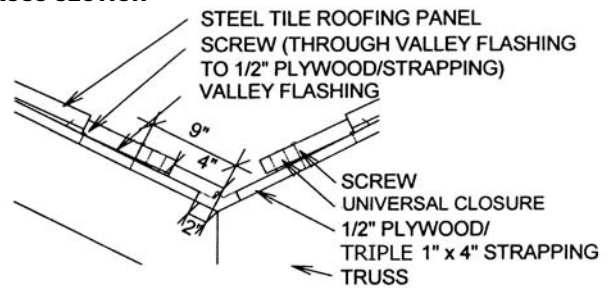

Detail 3.4 BOTTOM OF VALLEY FLASHING AT A DORMER

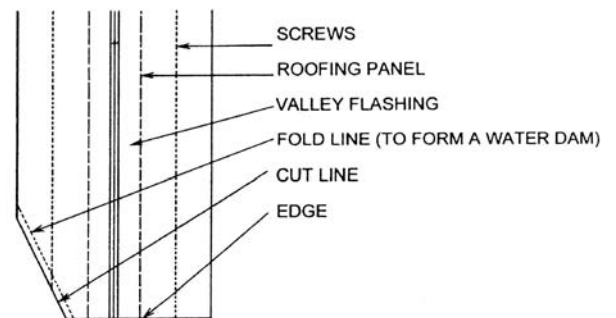

Detail 3.5: TOP OF VALLEY FLASHING AT A DORMER

PLACE FIRST VALLEY FLASHING

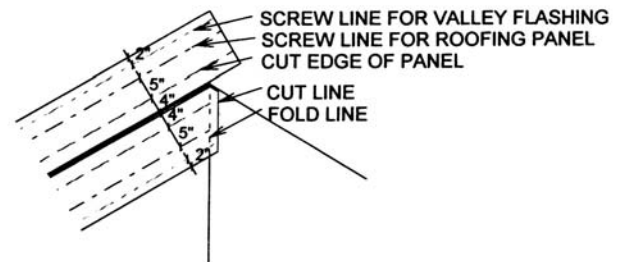

Detail 3.6:

THEN PLACE SECOND VALLEY FLASHING

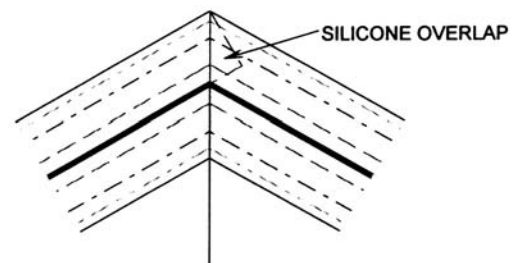

4) Install Gable Trim

There are two different types of gable trims available: regular gable flashing and F-gable trim with built-in gutter. The latter is ideal for graduating gables, as shown in Detail 4.2 The underflashing with the regular gable trim is another option for graduating gables, as shown in Detail 4.3. (If the last panel on a straight-gable roof ends at a low part of the wave, bend the edge of the roofing panel up with a hand bender before installing the gable trim.)

5) Install Ridge Caps

Ridge capping is required on all hips and ridges. Make sure the universal closure does not go too far under the capping. The same applies to hips. There are three typical ridge caps, as shown in Details 4.5-7. When screwing the caps down, place screws through the high part of the wave, so the caps do not bend up and down. Always start installing ridge caps at the bottom of a hip. Use a chalk line to install the ridge cap in a straight line. At a three-way intersection, fit the two hip caps together first and then fit the top ridge cap to them, as shown in Detail 4.4.

Install the end caps for ridge and hip caps. Fold the sides down and fasten with small screws or pop rivets.

Tip: Complete work on all F-gables, eaves and valleys before starting main roof installation. You can also do the closures as you go, one roll at a time.

Detail 4.1

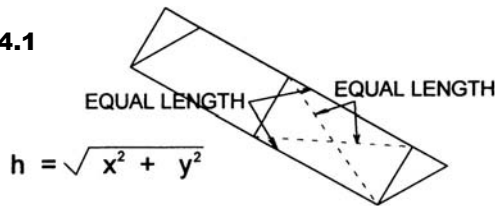

Detail 4.2

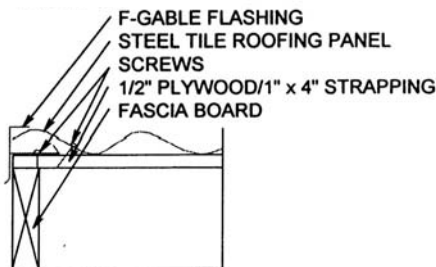

Detail 4.3

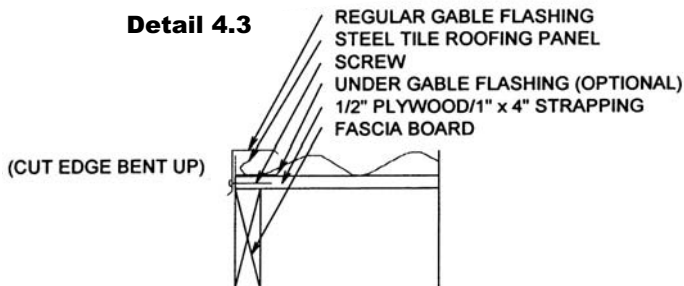

Detail 4.4

INSTALL THIS RIDGE CAP FIRST. ONLY THE LENGTH HAS TO BE TRIMMED.

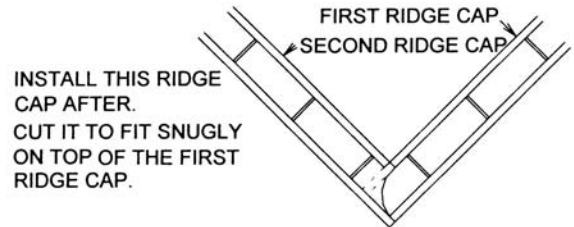

INSTALL THIS RIDGE CAP AFTER. CUT IT TO FIT SNUGLY ON TOP OF THE FIRST RIDGE CAP.

INSTALL HIP CAPS FIRST

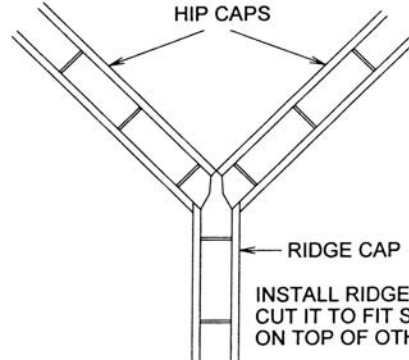

INSTALL RIDGE CAP LAST. CUT IT TO FIT SNUGLY ON TOP OF OTHERS.

Detail 4.5

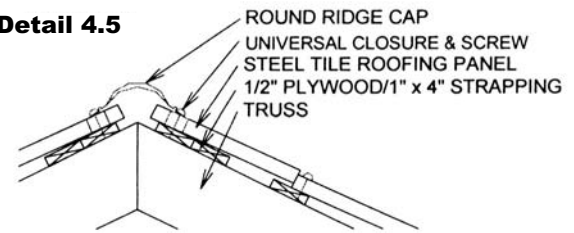

Detail 4.6

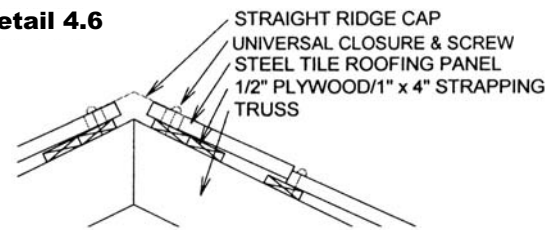

Detail 4.7

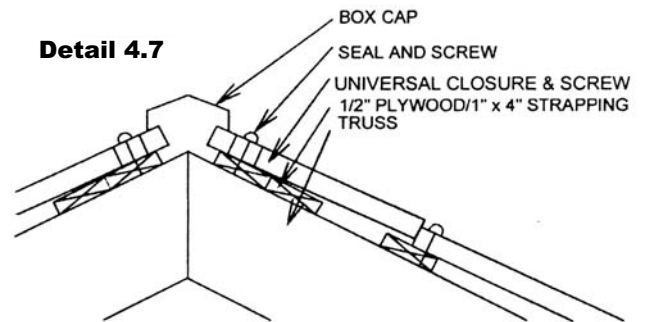

Detail 4.8

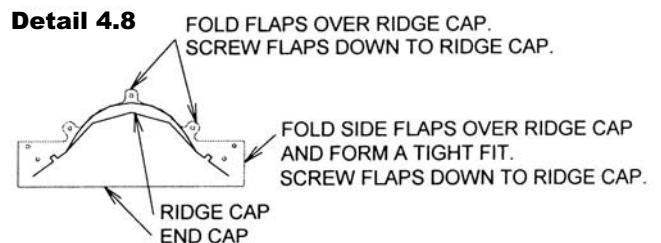

6) Install Closures

Nail through the closures to keep them in place. The Katola profile should have universal closures at the ridge and the eaves. However, you may eliminate the eaves' closures to increase airflow in reroofing applications. There should also be universal closures on both sides of all valleys and hips.

Fastening: Fasten screws with washers properly. Avoid deforming the roofing panels and the washers. If the washer becomes deformed during fastening, then it is too tight. If it is not visible, then it is too loose (see detail below).

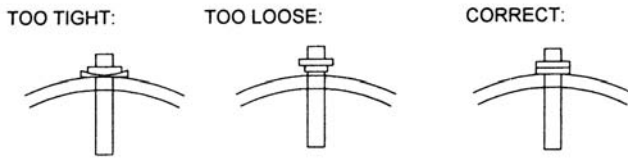

Screw down the entire panel according to these details. Always place the screws on the top of a wave and just below a step in the panel if possible. Screw through the closures at each wave at the top and bottom of each panel.

The Steel Tile screws are double-dipped galvanized steel, with a zinc layer and an organic layer for extra protection. They have a special bonded neoprene rubber washer, with a metal cap over it that is powder coated to colour-match the roof. The screws are self-tapping when a bit of pressure is applied. For fastening to heavy-metal purlins, ask about Driller Screws.

Flashing: Install pipe flashings around vent pipes, hydro stacks, etc., using Steel Tile approved silicone between the pipe flashing and the roofing panel. Screw the pipe flashing down to form the profile of the roofing panel. Seal edges with the silicone, as shown in Detail 5.1.

When fitting panels against a wall, ridge, hip chimney or skylight, or cutting the last sheet, you need to create a "dam" to ensure that water cannot get behind or under the panel. Always turn the edge of the roofing panel up about 1 1/2" with a hand bender and then install the appropriate flashing on top. Follow Details 5.2-4.

Detail 5.5:
OUR UNIVERSAL CLOSURE IS APPROXIMATELY 2" X 2" AND WILL COMPRESS TO ANY PROFILE.

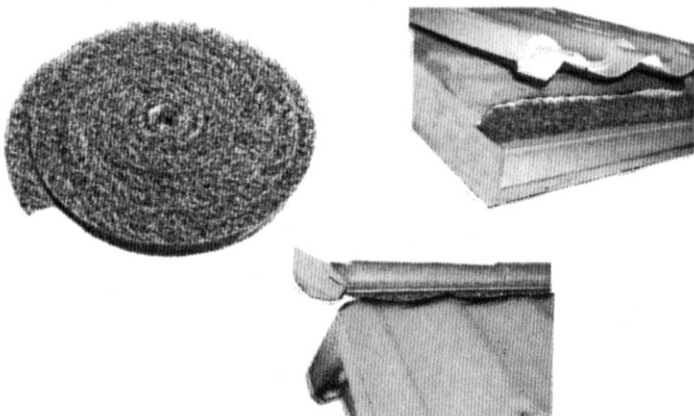

Tip: So the dam has a nice appearance, trim it but not flush with the fascia board. Let it hang past about 1" from the fascia board. At side cuts the dam should be tapered, so the panel is about 1/2" wider at the top than the bottom, to ensure easy overlapping of the next panel.

Detail 5.1

NOTE: IF STRAPPING IS USED
MAKE SURE TO STRAP AROUND THE PIPE.

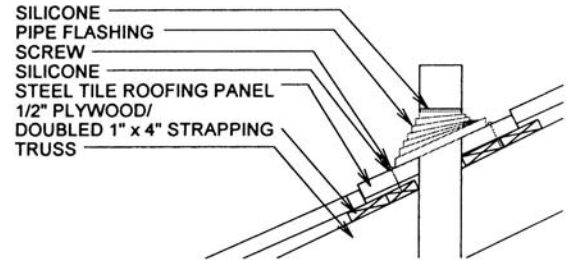

Detail 5.2

WALL
SILICONE
WALL FLASHING
UNIVERSAL CLOSURE & SCREW
SCREW
STEEL TILE ROOFING PANEL
1/2" PLYWOOD/1" x 4" STRAPPING
TRUSS

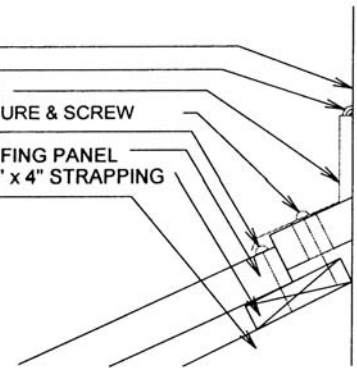

Detail 5.3

WALL
SILICONE
WALL FLASHING
SILICONE
UNIVERSAL CLOSURE & SCREW
STEEL TILE ROOFING PANEL
(BENT UP WITH HAND BENDER)
UNDER WALL FLASHING
1/2" PLYWOOD/1" x 4" STRAPPING
TRUSS

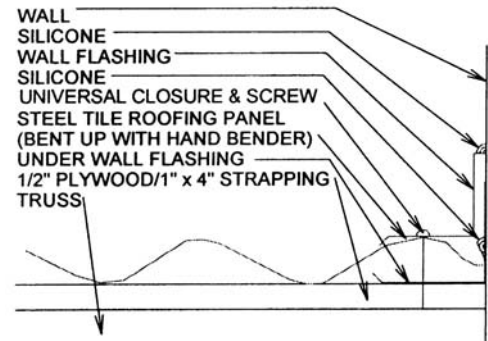

Detail 5.4: NEW CONSTRUCTION

SIDING
WALL SHEATHING
WALL FLASHING NO RETURN
UNIVERSAL CLOSURE & SCREW
SCREW
STEEL TILE ROOFING PANEL
1/2" PLYWOOD/1" x 4" STRAPPING
TRUSS

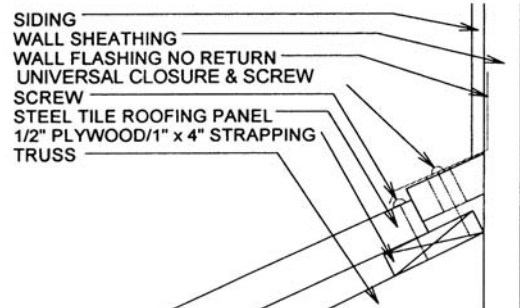

At Skylights and Chimneys: Skylights should be curb-mounted on a 2" x 6" frame. Use skylight/chimney flashings on the two sides and bottom. Install the bottom first and then install the side flashings, so they will overlap the lower flashing. Cut the ends of the side flashings and apply Steel Tile approved silicone on all overlaps.

Always use junction sheets on top of chimneys and skylights. Install the junction sheet 4" - 5" to go underneath the roof panels (it must be at a $\pm 90^\circ$ angle). If the skylight or chimney is wider, two or more junction sheets may be needed. If this happens, overlap the junction sheets 8" to 12" and use approved silicone between them. Cut sideways into the roofing panel carefully, making sure that side-cuts always end 6" or 7" past the side face. Cut the vertical ends of the junction sheet at an angle.

Use Steel Tile approved silicone between the roofing panel, junction sheet and the flashing, then screw them down to form a tight fit. Always be sure to install a closure between the lower flashing and the roofing panel. Follow Details 6.1 - 3

Detail 6.1:

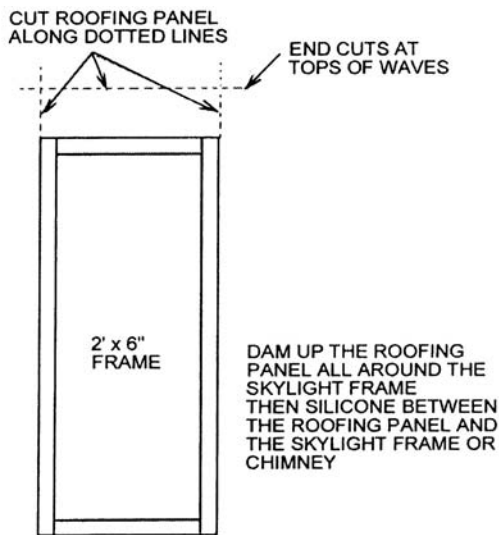

Detail 6.2:

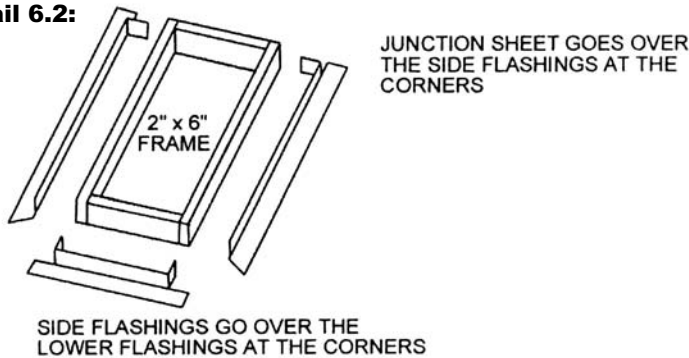

Detail 6.3:



Turbines: See package installation instructions, and refer to Detail 6.4.

Transition Trim: This is used for changes in the roofs pitch. Follow Detail 6.5

Snowlok or Snow/Ice Stop: These need to be installed on roof areas where sliding snow and ice can pose a safety hazard. See Detail 5.6

Tip:

In areas of the panels where heavy dirt deposits dull the surface, a solution of water and detergent may be used: 100 ml (1/3 cup) of a typical laundry detergent per 4.5 litres (1 gallon) of water. A soft bristle brush should be used for scrubbing, followed by a clear water rinse.

Detail 6.4: BEFORE POSITIONING THE TURBINE ON ITS BASE, INSTALL OUR PAN

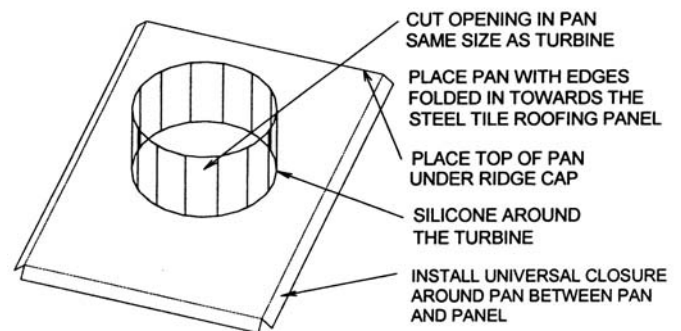

Detail 6.5:

Transition Trim: used for changes in roof pitches

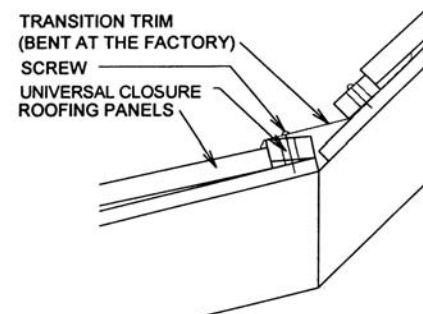

Detail 6.6:

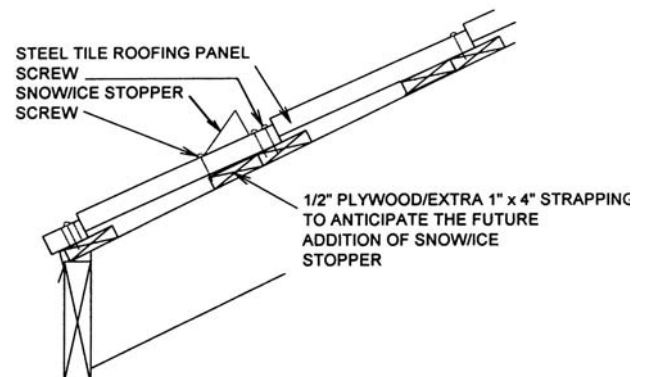

7) Install Roofing Panels

Katola panels can either be installed from left to right (the default direction, as viewed from the ground), or right to left. However, for the best look, the bottom row of panels should be installed left to right. If it is installed the other way, some minor "sawtoothing" might become apparent (because of the difference between panel overlap and underlap lengths).

It's possible to "backsheet" by partially lifting a fastened panel up and placing the next one underneath. This may be necessary on a steep-pitched roof, as panels tend to slide down and cause the edge to creep past the eaves. There should always be a 3/8" overhang.

Tip: *Use extreme caution when handling roofing panels on windy days. The profiled design of Katola panels strengthens the sheets but care must be exercised when moving them. Hang onto the panels at the step to avoid creasing the exposed overlap.*

Working Up and Down: With Katola panels, you can work from bottom to top or from top to bottom. Since the bottom row of panels should be whole, keeping their factory-cut edges intact, it is usually easier to work from bottom up. If there is any variation during installation, the top panels can be cut to accommodate it.

In some cases it might be better to work from top to bottom if, for example, you are installing a roof with a steep pitch. In this case, measure from the bottom in 16" increments to the last panel, then drop this point down 1 1/2". This allows a margin of error and ensures an overhang at the eaves. If the bottom row sticks out too much, it can be pushed back a bit under the row above.

Tip: *Panels can be walked on. However, step only on the bottom of the wave, below a step. Avoid walking on roofing panels when wet or covered with snow, they become very slippery. For the best traction on a roof, wear running shoes or other rubber-soled footwear.*

Laying the Panels Straight: Start laying the panels from gable ends or hips, but always into valleys, because buildings are not necessarily square. It is important to start square by using a chalk/straight line, or cross-measuring (as in Detail 7.1), or by simply fastening three to four panels together and aligning them as a unit.

When stitching panels together, fasten the first panel to the roof as square as possible with the eaves (leaving a 3/8" overhang). Then stitch three panels to the first panel (screw the panels together, but penetrate only the panels and do not go into the plywood or strapping) and move the panels as a unit to line up with and follow the eaves. When the panels are square, fasten them to the plywood or strapping.

After laying the first row, chalk lines every 5' 4", 6' 8" or 8' (all increments of 16") as a guideline for laying the panels straight. If measurements vary from the line across one side to the other, adjust the panels accordingly, maintaining a straight line.

Tip: *Always measure from step to line for straightening panels, never from bottom edge or top face (because these may not be exactly square).*

Fastening the Panels: Screw the bottom only, and screw down every panel completely, as shown, before fastening the next panel. Always screw just below the step (1/4" to 1/2") in the high rib, making sure that every rib is fastened. If the roof is uneven and wavy, screws may be required in the occasional low rib to ensure a tight fit. Again, keep screws close to the step.

Tip: *For a more pronounced wave pattern in the roof, the Katola panels can be placed at shorter increments (14" or 15", for example). The strapping and measurement of panel placement would have to be adjusted accordingly.*

Detail 7.1

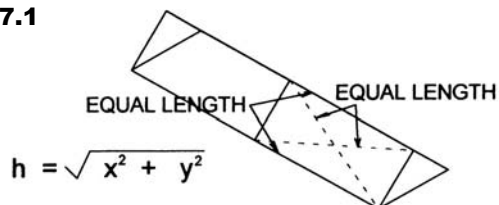

Cutting Panels: Use a chalk line to get a straight line. Cutting can be done easily on the ground. Another way is to rough-cut panels on the ground and then do exact cuts up on the roof. Never use a circular saw, or any other saw with a rotating blade, to cut the panels. These saws produce friction heat that could damage the paint and zinc coatings. There are some power shears and nibblers that are acceptable for the job (consult your building supplier or call Steel Tile). The simplest way to cut the panels is with a good-quality pair of offset hand snips. They don't create heat and tend to seal the galvanized layers together.

Tip: When installing the panels, consider staggering the joints. This way four pieces of panel will never overlap, making it very difficult to get a screw through.

Dormer Valleys: Leave approximately a 4" space between the cut end of the panel and the middle of the valley flashing, as shown in Detail 8.1. Cut the roofing panel as shown in Detail 8.2. Be careful cutting sideways into the panel (if you go too far, you'll need sealant to fill in the cut). Apply Steel Tile approved silicone to the valley flashing and the main roofing panel, as shown in Detail 8.2. Place the universal closure at the valley return and screw as far as possible, 6" from the panel edge (as shown in Detail 8.1). See "Install Seals."

Tip: Panels can be lapped in valley areas to ensure that seams face in the opposite direction of snow and water flow.

To install the ridge cap on the top of a dormer, bring the cap under the main roofing panel, as far up as possible, and seal it with silicone. See "Install Ridge Caps."

Tip: Panel waste from a valley cut can be used to fill in gable or hip cuts, and vice-versa. But when using the scrap, remember that panels or panel pieces cannot be turned upside down.

Tip: When cutting with Power Shears or Nibblers you may have "cuttings" accumulate on the panels. Make sure to completely clean these "cuttings" from the roof as you go. Failing to do so may damage the painted surface or cause discoloration.

Detail 8.1:
CROSS SECTION

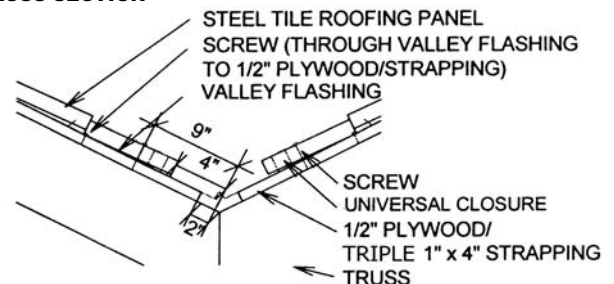

Detail 8.2:
CUTTING PANEL

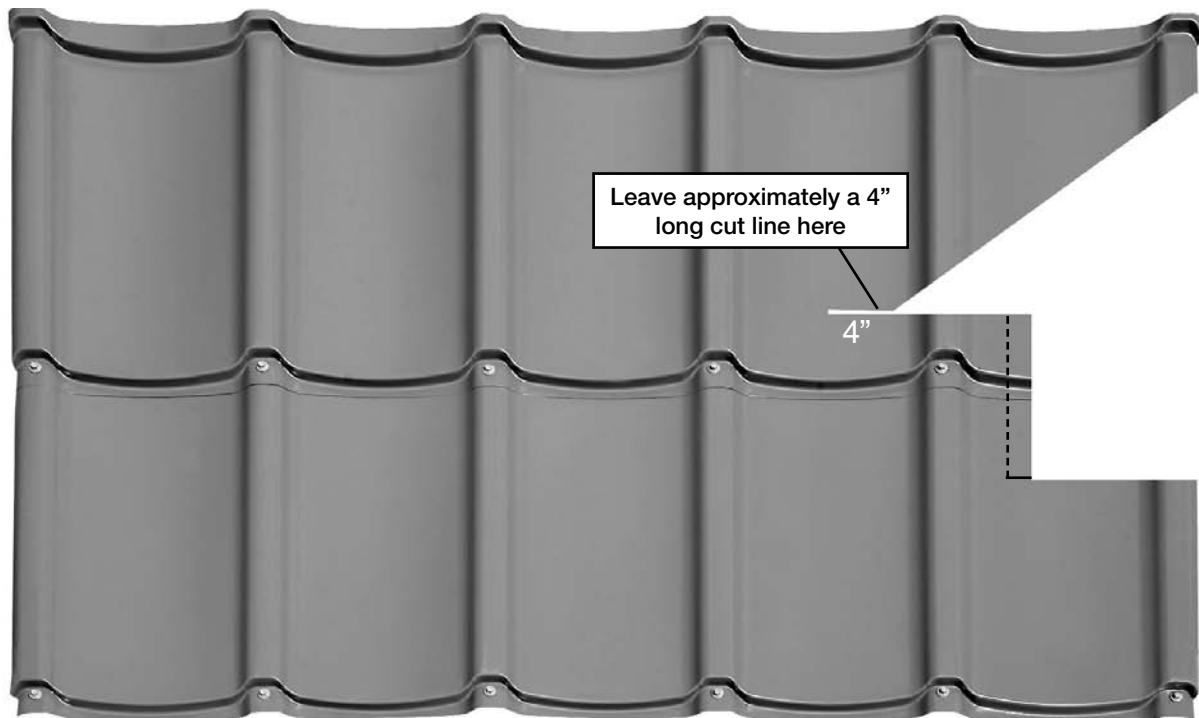

Trims Available

Steel Tile offers a complete range of trims, flashings and caps to protect seams, intersections and projections from water seepage.

Regular Gable Flashing

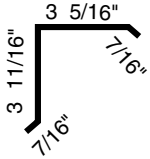

**Transition Trim
(Bent at the Factory)**

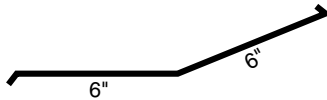

Wall Flashing

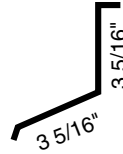

F-Gable Flashing

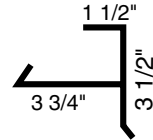

Regular Gable Flashing and Under Gable Flashing (Optional)

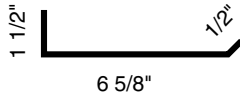
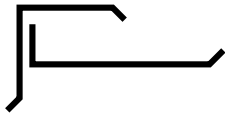

Eaves Trim

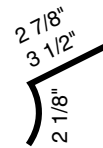

Wall Flashing and Under Wall Flashing

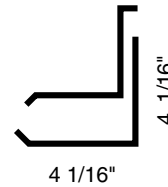

Wall Flashing No Return



**Box Cap
(Special Ridge Cap 16" Cut)**

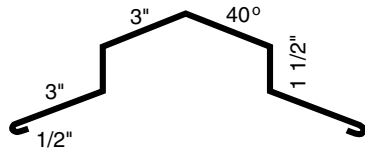

Straight Ridge Cap

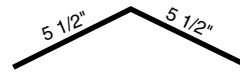

Snow / Ice Stop



Valley Flashing

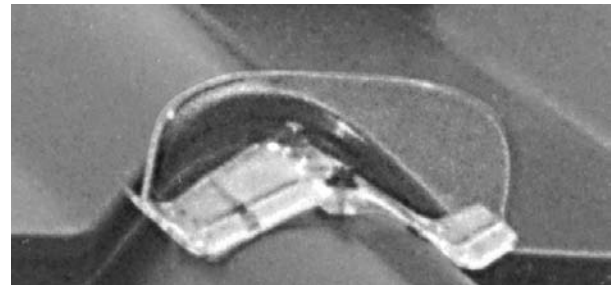
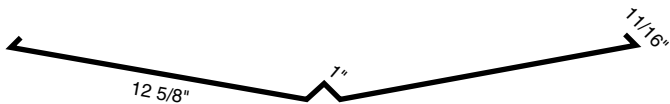

SNOWLOCK

Turbine Pan

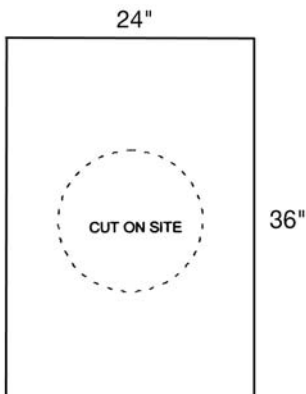

PIPE FLASHINGS
COME IN 3 SIZES:
REGULAR PIPE FLASHING 3-4"
LARGE PIPE FLASHING 4-6"
SUPER PIPE FLASHING UPTO 14'

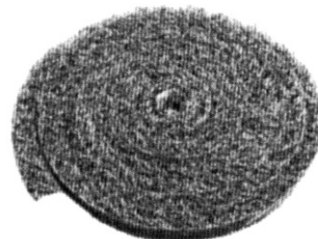
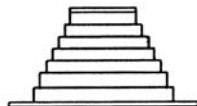

UNIVERSAL CLOSURE
PRICED BY THE FOOT
PACKAGED IN 30FT.
LENGTHS



3487 Thomas Street, Innisfil, ON Canada L9S 3W4
P. 705-436-1723 F. 705-436-6329
1-800-461-5567
Web: www.steeltile.com